

Universal-Dispenser Touchless T 400 / T 1000

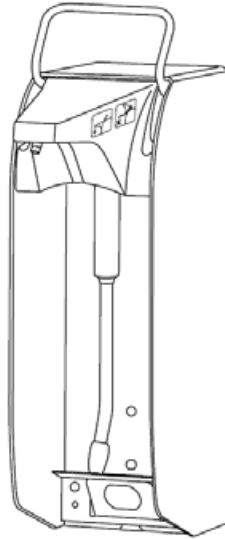

Installation and Operating instructions

EN

EN 1. Indications for use of the manual, 2. Safety information



Please read through carefully these operating instructions prior to initial operation and keep it. In case of a resale of the apparatus, please pass on these operating instructions to the buyer.

Front

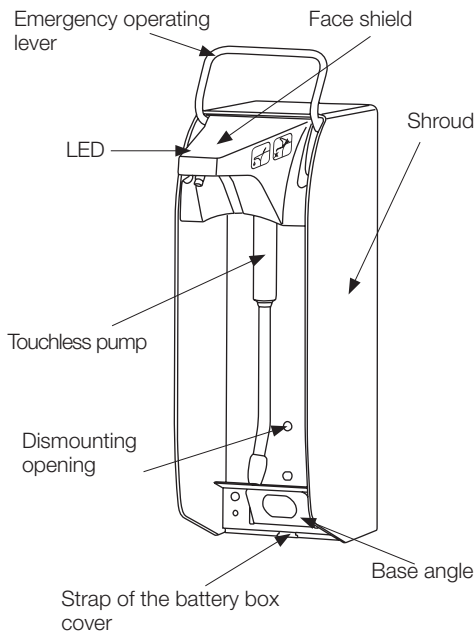

Rear

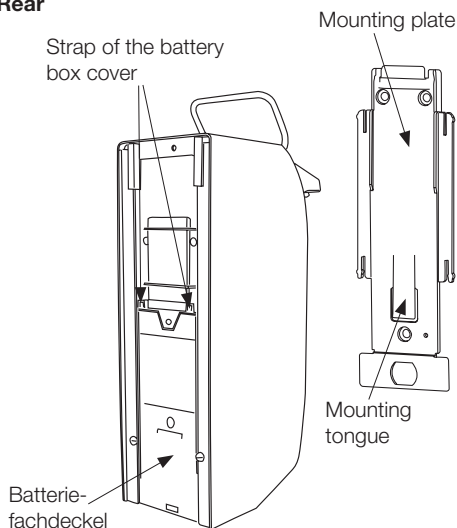

Sensor area

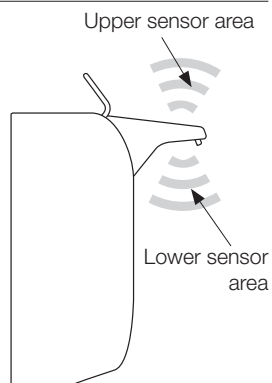

1. Indications for the use of the manual

The following symbols are used in the instructions:



Safety reference:

Non-observance may cause damage to persons or defects to the device.



Notice:

Supplementary information about the operation of the unit.













2. Safety information



The manufacturer does not assume any liability for damages in the case of:

- Defects at the appliance caused by mechanical influences or overvoltage
- Changings at the appliance without express approval of the manufacturer
- Use for the other purposes than that mentioned in the application

2.1 General safety and safety during operation of the appliance

-  • Repairs at the appliance may exclusively be carried out by persons authorized by the manufacturer. Important dangers may occur by unexpected repairs. In case of a necessary repair please contact the the manufacturer service department.
-  • Suspend the appliance on a dry and splash-proof place. Keep dry and never drown the appliance under water.
-  • This appliance is not a toy. Keep and use it out of the reach of children.
-  • The appliance is not suitable for the metering of other than the indicated media.
-  • Exclusively operate the appliance with leakproof batteries of the same manufacturer and type and with the same charging condition. Only use batteries with indicated size / type D.
-  • Do not operate the appliance with rechargeable batteries (accumulators).
-  • Never use force. The appliance needs not be disassembled, no repairable parts.
-  • Do not expose the appliance to thermal radiation and heat.
-  • Only fill the appliance with the indicated substances in accordance with the intended use.
-  • There are no dismantable parts with the exception of pump, receptacle, battery cover, mounting plate, batteries, locking plate (accessories)
-  • The appliance is not autoclavable and cannot be cleaned in the dishwasher.
-  • The apparatus must not be cleaned with water jets or by means of a high-pressure cleaner.

3. Intended use



The appliance is suitable for the touchless hands' disinfection. Furthermore the appliance can be used for the dispensing of liquid soaps for washing one's hands.

The apparatus is exclusively designed for battery operation.

Always hang the dispenser upright onto the wall. The dispenser must not be placed freely. The appliance is designed for indoor use only.

Use the appliance for hands' disinfection and cleaning with the usual application cycles.

Ambient conditions:

-  • Only use the appliance in a dustless environment.
-  • Pay attention to that the apparatus is only used at a relative air moisture of <90% (not condensing).
-  • Only use this apparatus at room temperature.

Media to be used:

- ⚠ • The used medium has to be free-flowing at room temperature.
In case of doubt please test your medium for suitability.
- ⚠ • The appliance is designed for operation with disinfectants or with liquid soap.
- ⚠ • The appliance is not suitable for operation with abrasive and aggressive media.
- ⚠ • Foodstuff as medium is not permissible.

3.1 Operation of the dispenser according to the regulations

In order to always guarantee an optimum functioning of the dispenser the following has to be observed:

- Only use disinfectants or thin liquid soap.
- The dispenser may not be located close to radiation-emitting or statically charged objects while it is used.
- The dispenser only meters with closed faceshield.
- The emergency lever has to be actuated exclusively in case of a breakdown of automatic function!

4. Dispenser components / scope of delivery

Model	No.
Universal-Dispenser Touchless T 400	6000-049-27
Universal-Dispenser Touchless T 1000	6000-049-28

4.1 Accessories

Accessory for Touchless:	
Drip tray	6000-049-29

4.2 Filling goods for the Universal Dispenser Touchless T 400

HD 410 hand disinfection 400-ml bottle	CDH410B3150
HD 412 essential hand disinfection 400-ml bottle	CDH412C3150
HD 435 wash lotion 400-ml bottle	CCH435C3150
HD 440 skin care lotion 400-ml bottle	CCH440C3150

4.3 Filling goods for the Universal Dispenser Touchless T 1000

HD 410 hand disinfection 800-ml bottle	CDH410B4750
HD 412 essential hand disinfection 800-ml bottle	CDH412A4750
HD 435 wash lotion 800-ml bottle	CCH435A4750

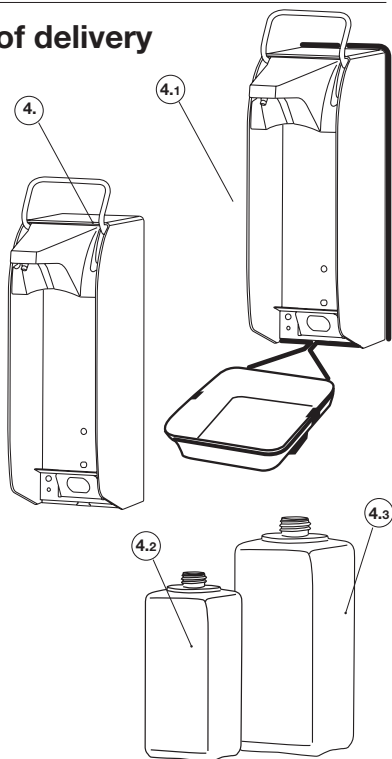

5. Technical description

The appliance recognizes by means of a touchless sensor technique and a hand approaching the outlet and, thus, automatically releases a pump stroke.

The appliance meters free-flowing media by means of a removal valve suction pump from an exchangeable receptacle which is inserted into the dispenser.

6. Mounting of the dispenser

6.1 Preparation of the installation

One has to take care by means of adequate equipment that no medium pours out on the floor.

 • Prior to use of new filling media, tests are required!

 • Please pay attention to that during installation, no radiation-emittent object (i. e. X-ray apparatus, mobile telephone, ultrasound device, direct illumination over the dispenser, etc.,...) is in the near proximity.

Electromagnetic interference sources and/or radiating electric fields may impair the function!

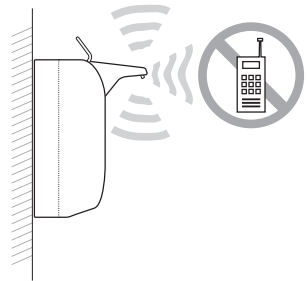

Prior to the mounting of the dispenser please observe the following

• Required place above the dispenser:

40 mm (for putting on and removing from the mounting plate).

Please take the required place below the dispenser from the dimensioned sketch.

• Suitable mounting height:

130–135 cm, measured from the floor up to the upper edge of the dispenser.

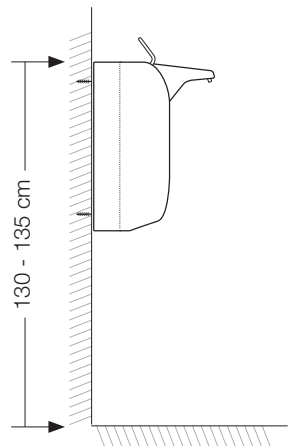

6.2 Mounting

For the mounting and going into operation of the **Universal Dispenser Touchless** please keep the following steps in sequence.

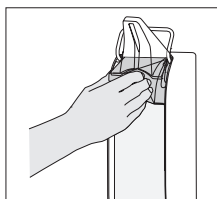

Open faceshield. Therefore, pull it slightly to front and guide it upwards.

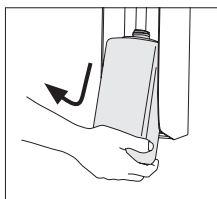

When delivered, mounting plate is in the dispenser. For the removal of the mounting plate slightly lift the receptacle in the dispenser and remove it from the dispenser.

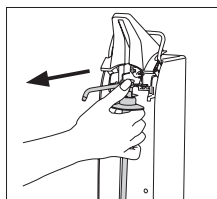

Remove the pump (see "pump change", and leave the faceshield open.

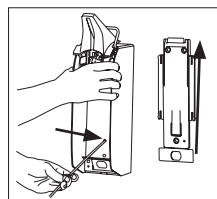

Insert screwdriver through the dismounting opening and press down mounting tongue of the mounting plate. Pull dispenser upwards with pressed mounting tongue.

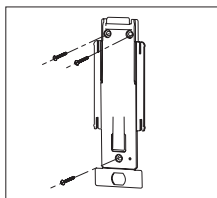

Fix mounting plate at the wall in desired position by means of dowels and screws. **Drilling diagram see "technical data".**

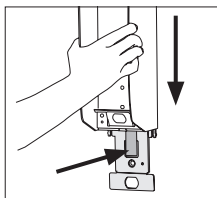

Slide the dispenser from above onto the mounting plate till the locking tongue snaps in.

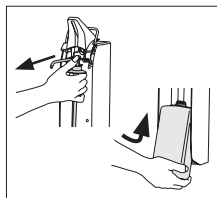

Reinsert first the pump and then the receptacle.

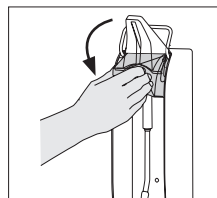

Close faceshield.

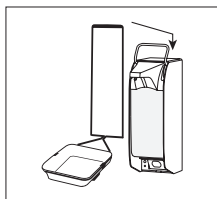

Install drip tray by hanging up above the dispenser.

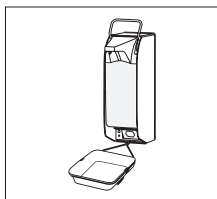

Ready.

7. Going into operation

7.1 Insert the batteries

The back of the dispenser must therefore be accessible (mounting plate removed).

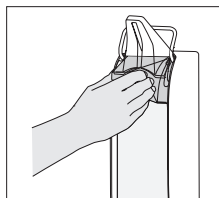

Open faceshield.

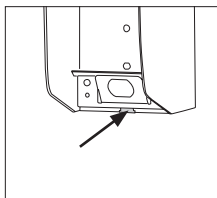

Open battery cover by releasing the lower strap on the front side underneath the base angle. Open the batt. cover.

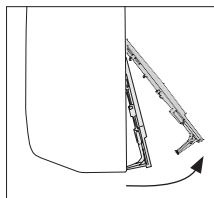

Unhinge the cover and put it beside.



Insert the batteries in the dispenser. **Pay attention to correct polarity and sequens as above!**

- i** • If the dispenser is not used for a longer period than 3 months, batteries should be removed in order to prevent unwanted discharge.

- After correct insertion of the batteries an acoustic signal sounds.
- Slide the dispenser from the above onto the mounting plate.
- Close the faceshield: now the dispenser starts with the first gauging.
- The noise level of the unit is below 70 dB (A).

- i** • If the batteries have not been inserted with closed face shield, the measuring procedure has to be carried out once again after having put the dispenser on the mounting plate by shortly opening and closing the faceshield such as with the change of the pump. This procedure is explained below in more detail.

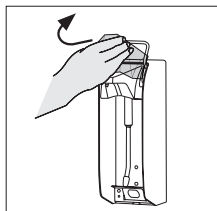

7.2 Use of the appliance

- i** • Prevent unwanted pump strokes by opening the face shield and keeping it open during exchange. Body parts as well as objects have to be removed immediately for about 10 seconds after having closed the faceshield because dispenser adjusts itself.

The LED lights while the dispenser gauges. As soon as the light is out the dispenser is ready for operation.

After change of receptacle or pump, the medium has to be primed with several pump strokes (repeated pumping operation necessary).

- i** • With the correct opening and closing of the faceshield, a (different) acoustic signal sounds.

- After sliding dispenser onto mounting plate, insert pump and close the faceshield. The dispenser will adjust to the pump stroke size and the environment.
- Insert a receptacle filled with medium of your choice into the dispenser.

- !** • Make sure that receptacle is in correct safe position and cannot fall out the dispenser.

- Now you can use the appliance.

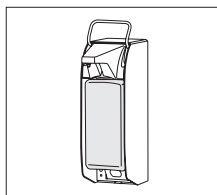

8. Basic operation

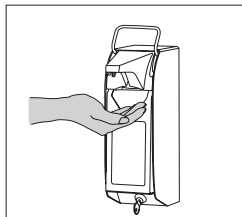

The actuation of the dispenser is effected if a hand approaches from below under the outlet. At a distance of approx. 4 cm the dispenser releases automatically a pumping process.

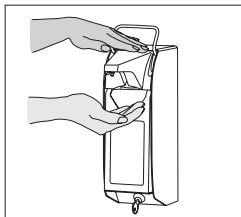

For further dispensing actions keep holding your hand below the outlet and approach the second hand from above to the face shield ('**virtual operating lever**'). This works only when having your other hand **first** under the outlet!

i • If you approach with only one hand from above without holding the other hand below the outlet, the appliance does not pump!

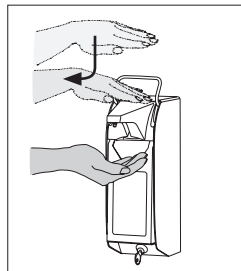

Approach the upper hand up to a distance of approx. 4 cm to the face shield - the dispenser actuates several times.

The dispenser meters as long as one of both hands is not removed - up to 5 times.

The complete action can be repeated as many times as you like.

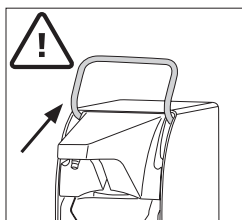

9. Pump change

! • The pump must only be changed if the emergency operating lever is in upper position!
Otherwise serious damages on the appliance may occur.

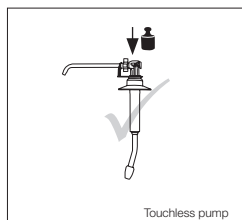

! • Please take care that only original **Universal Dispenser Touchless pumps** will be used.

The **Universal Dispenser Touchless pump** can be pressed down very easily.

EN 9. Pump change, 10. Exchange of receptacle, 11. Use of emergency operation lever

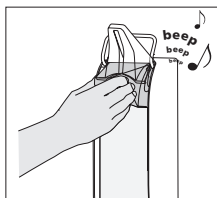

Lift the faceshield.
When opening, approach the facshield always from above in order to prevent unwanted pumping action.
After opening, an acoustic signal sounds.

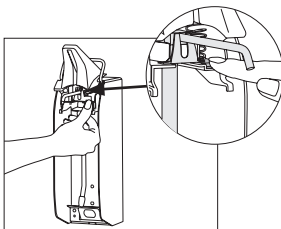

Push and hold the pump catch ("**PUSH**" button) with the finger and pull out the pump towards the front.

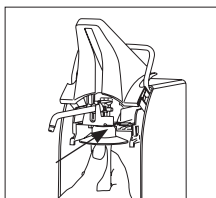

Reinsertion: Push in the pump from the front side into the intended guidance until it snaps in. Reclose the faceshield.

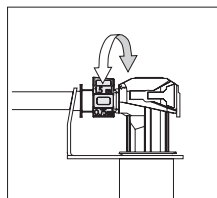

9.1 Change of the dosage

The dosage of the pump is adjusted to the maximum of approx. 1,5ml / stroke. If required, the dosage can be reduced in stages by turning the dosage piece (part of the pump) up to approx. 0,75 ml / stroke.

For this remove the pump from the dispenser.

⚠ • Use only pumps with the silicone bottle adapter! Please also take care that the bottle adapter sits always tight onto the bottle's opening so that no gas can exhaust.

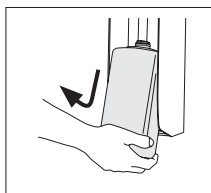

10. Exchange of receptacle

- Lift up the empty receptacle from below, draw it to the front and remove it from the dispenser.
 - Insert the filled-up receptacle from below into the dispenser. Please pay attention to the correct position of the receptacle.
 - If necessary, remove the locking plate before.
 - Please take care that only receptacle with an opening width of max. 45mm is used. Make sure that the bottle adapter sits tight onto the opening, so that no gas can exhaust from the receptacle.
- In order to avoid unintended pumping actions, take care that the faceshield is opened.

11. Use of the emergency operating lever

In case of a failure of the automatic functions (**for instance batteries low**) an operation by means of the emergency operating lever is possible.

⚠ • Only actuate the emergency operating lever in case of a failure of the automatic function !

Operation: For this purpose pull down the lever to the lower limit stop and return it again manually back up in the initial position.

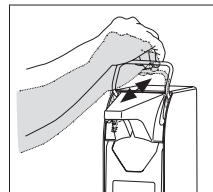

12. LED display

For protection against unintentioned actuation, electromagnetic interference sources and false handling are recognized and indicated by the lighting up of the LED. **As long as the LED lights up, the automatic pumping action is suppressed.**

-  • The LED also lights up during gauging.
When it expires, the dispenser is ready for operation.

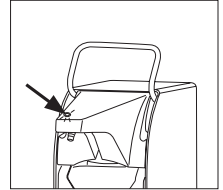

13. Maintenance & service / cleaning

13.1 Cleaning and attendance

The dispenser itself is maintenance-free with the exception of the battery exchange. For cleaning the dispenser remove the mounting plate and dismount the batteries. Cleaning of the dispenser only from the outside. Wipe the apparatus with a humid cloth.

Exchange the empty receptacle in time. If the suction valve is nevertheless clogged, please only pump hot water through it in order to restore the function.

Please only use hot water and do not use caustic (chlorous) purifiers or scouring powders !

- ⚠ • **By no means disassemble the appliance!**
- ⚠ • **Please pay attention to that the appliance is not submerged or exposed to water jets.**
- ⚠ • **The appliance can not be cleaned in a washer-disinfector and is not dishwasher-proof and is not autoclavable.**
- ⚠ • **The Touchless pump can be cleaned in a washer-disinfector and is dishwasher-proof and autoclavable. However it must rest for 6 hours after such a treatment before it is reinserted in the dispenser.**

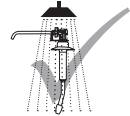

13.2 Exchange of battery

Test the battery level:

First of all approach one hand to the upper sensor and then the other hand to the lower sensor. Remain in this attitude for at least 3 seconds until the acoustic signal sounds:

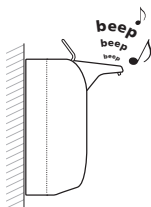

4 x = battery full	
3 x = $\frac{3}{4}$ full	
2 x = $\frac{1}{2}$ full	
1 x = $\frac{1}{4}$ full	

i • In case of weak batteries during normal use a short acoustic signal sounds instead of the pumping action to indicate that the battery has to be replaced.

13.3 In time refill of the medium

For an interruption-free hygienic supply the receptacle has to be exchanged in time.

14. Risks

In dealing with the **Universal Dispenser Touchless** please take notice of some important differences compared to our manually operated dispensers.

- The **Universal Dispenser Touchless** is not autoclavable.
- Never try to remove or exchange the pump when the **emergency operation lever** is not in the **upper position**!
- Use the emergency operating lever **only in case of a failure** of the automatic function!
- Do not carry out any repair at the appliance!

15. Disposal

Dispose of packing material into the corresponding recycling plants. At the end of the lifecycle pls contact the next recycling centre or ask your specialized dealer about applicable disposal regulations.

16. Technical data

Shroud.....aluminium, anodized

Lever.....stainless steel

Mounting plate.....plastic

Drip tray.....plastic, stainless steel

Pump.....plastic and stainless steel, removable

Wall mounting.....with dowels and screws

Conformity.....RoHS compliant,  according to machinery directive 2006 / 42 / EC & EMC directive 2004 / 108 / EC

Manufacturer.....Ophardt Ireland, Tubbercurry Road, Ballymote, Co. Sligo, Ireland

Voltage.....7,5 Volt DC

Batteries.....5 mono-cells type ANSI D

Safety class.....IP22

Dimensions in mm.....W 92 x H 330 x D 210 mm
(with drip tray in mm).....W 150 x H 410 x D 310 mm

Total weight.....1250 gram
(without Batteries)

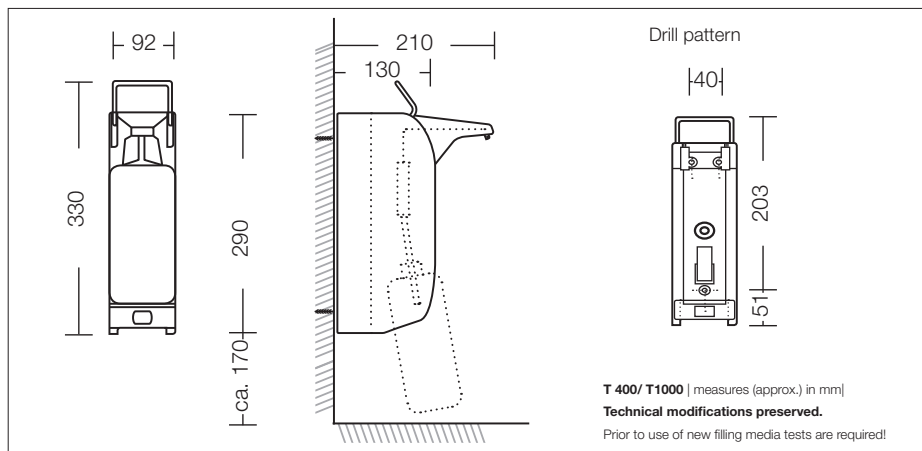

EN 17. Troubleshooting

Characteristic	possible cause	solution
1. After insertion of the batteries no acoustic signal sounds	<ul style="list-style-type: none"> Batteries are low. Batteries were not inserted correctly. Faceshield is closed while insertion. 	<ul style="list-style-type: none"> Insert new batteries. Open the battery box, insert batteries according to the diagram. Pay attention to polarity and the sequence. Remove batteries, open faceshield, insert new batteries again.
2. During opening and closing of the faceshield no signal sounds	<ul style="list-style-type: none"> Batteries are low. No batteries inserted. Battery contact interrupted. Appliance defective. 	<ul style="list-style-type: none"> Insert new batteries. Insert batteries. Restore battery contact. Call after-sales service.
3. The LED lights up if a hand is held below the outlet and no media is dispensed	<ul style="list-style-type: none"> Operating error. Appliance recognized a disturbance (unwanted radiation influence or electric field). 	<ul style="list-style-type: none"> Operate appliance as described above. Pay attention to the sequence of actuation in the sensor areas. Avoid contact with the faceshield. A) Remove all electromagnetically charged or emitting appliances out of the reach of the sensor. B) Open and close the face shield and quickly remove hands and / or other disturbing objects. Wait for a short time until the dispenser has gauged. Then actuate the dispenser as usual. C) Remove receptacle and pump and reinsert them. D) Make sure that pump sits correctly.
4. The appliance seems to function normally but no medium is dispensed	<ul style="list-style-type: none"> No receptacle is inserted. No pump is inserted. Pump is clogged. Receptacle is empty. Pump lost contact to the medium. An unsuitable medium has been used. 	<ul style="list-style-type: none"> Insert full receptacle. Insert Touchless pump into the dispenser. Remove pump and clean it. Replace receptacle. Carry out the dosage process several times. If it doesn't function, the pump is possibly clogged. Use different medium. Clean pump thoroughly before.
5. An acoustic signal only sounds if the hand is held below the outlet and no media is dispensed	<ul style="list-style-type: none"> Batteries are low. 	<ul style="list-style-type: none"> Replace batteries.
6. After insertion of the locking plate the appliance does not function as usual	<ul style="list-style-type: none"> Appliance has not yet adjusted to the locking plate. 	<ul style="list-style-type: none"> Wait (max for a few minutes).
7. The appliance doses too much or not enough medium	<ul style="list-style-type: none"> Dosage adjustment is not adjusted correctly. 	<ul style="list-style-type: none"> Carry out dosage adjustment on the pump.

DÜRR DENTAL AG
Höpfigheimer Strasse 17
74321 Bietigheim-Bissingen
Germany
Fon: +49 7142 705-0
www.duerr.de
info@duerr.de

